

PRISMA 160 SPUMANTE

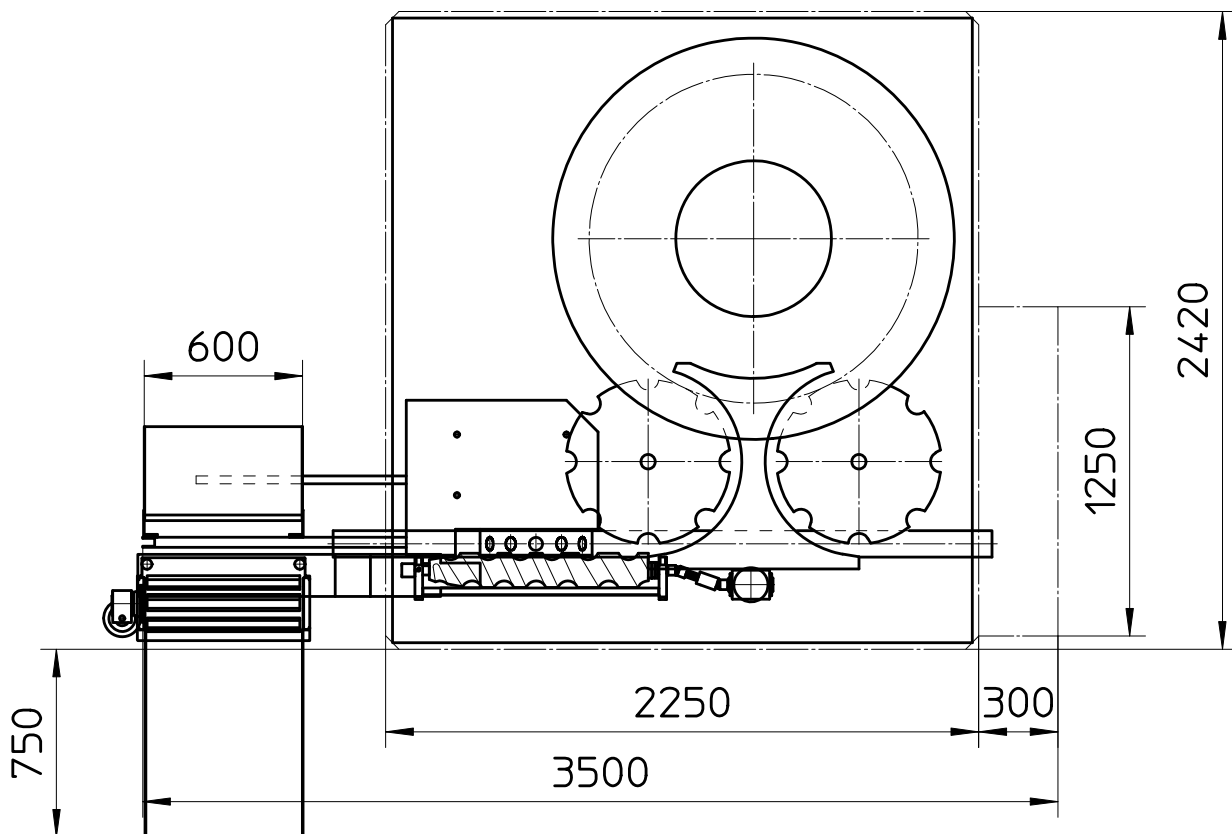
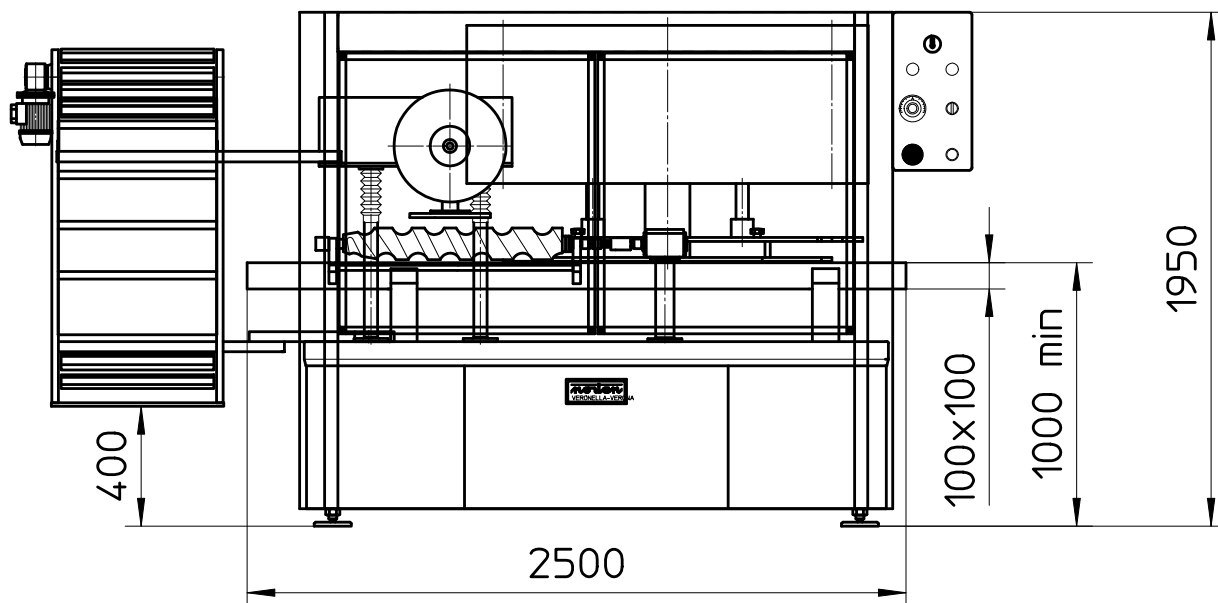

PESO WEIGHT POIDS	Kg	2000	DIAMETRO BOTTIGLIE BOTTLE DIAMETER DIAMETRE BUEILLE	±2 Min. mm Max.	50 115	CAPACITA' MAGAZZINO WAREHOUSE CAPACITY CAPACITE MAGASIN	Caps.	1500
TIPO CAPSULE CAPSULE TYPE TYPE DE CAPSULE	---	SPUMANTE	MOTORE MOTOR MOTEUR	Kw	1,5	PRODUZIONE OUTPUT FOR HOUR RENDEMENT	B/h Min. Max.	1200 14000
LUNGHEZZA MAX CAPSULE MAX. CAPSULE LENGHT LONGUEUR MAX CAPSULE	mm	130	CONSUMO ARIA AIR CONSUMPTION CONSOMMATION D'AIR	L/min	450	CONSUMO ELETTRICITA' ELECTRICITY CONSUMPTION CONSOMMATION COURANT	Kw	3
DIAMETRO MAX CAPSULE MAX. CAPSULE DIAMETER DIAMETRE MAX CAPSULE	mm	52	COM. A BASSA TENSIONE LOW TENSION COMMANDS SECURITE	Volt	24			
ALTEZZA BOTTIGLIE BOTTLE HEIGHT HAUTEUR BOUTEILLE	±10 Min. mm Max.	235 360	TENSIONE DI ALIMENT. FEEDING VOLTAGE COURANT	Volt	220/380 Hz 50			

COMPILATO
DATA
FIRMA
CONTR.

NOTE

Scala : 1:30